

Features

ISSUE 1

December 1997

- Transformerless 2-wire to 4-wire conversion
- Battery and ringing feed to line.
- Off-hook and dial pulse detection.
- Ring ground over-current protection.
- Constant current feed with constant voltage foldover.
- Relay driver.
- Power Denial.
- Wide Operating Range.

Ordering Information

MH88612BV-K 20 Pin SIL Package

0°C to 70°C

Applications

Line interface for:

- PABX
- Intercoms
- Key Telephone Systems
- Control Systems

Description

The SLIC provides a complete interface between a switching system and a subscriber loop. Functions provided include battery feed and ringing feed to the subscriber line, 2-Wire to 4-Wire hybrid interfacing, constant current feed and dial pulse detection. The device is fabricated using thick film hybrid technology in a 20-pin single in-line package.

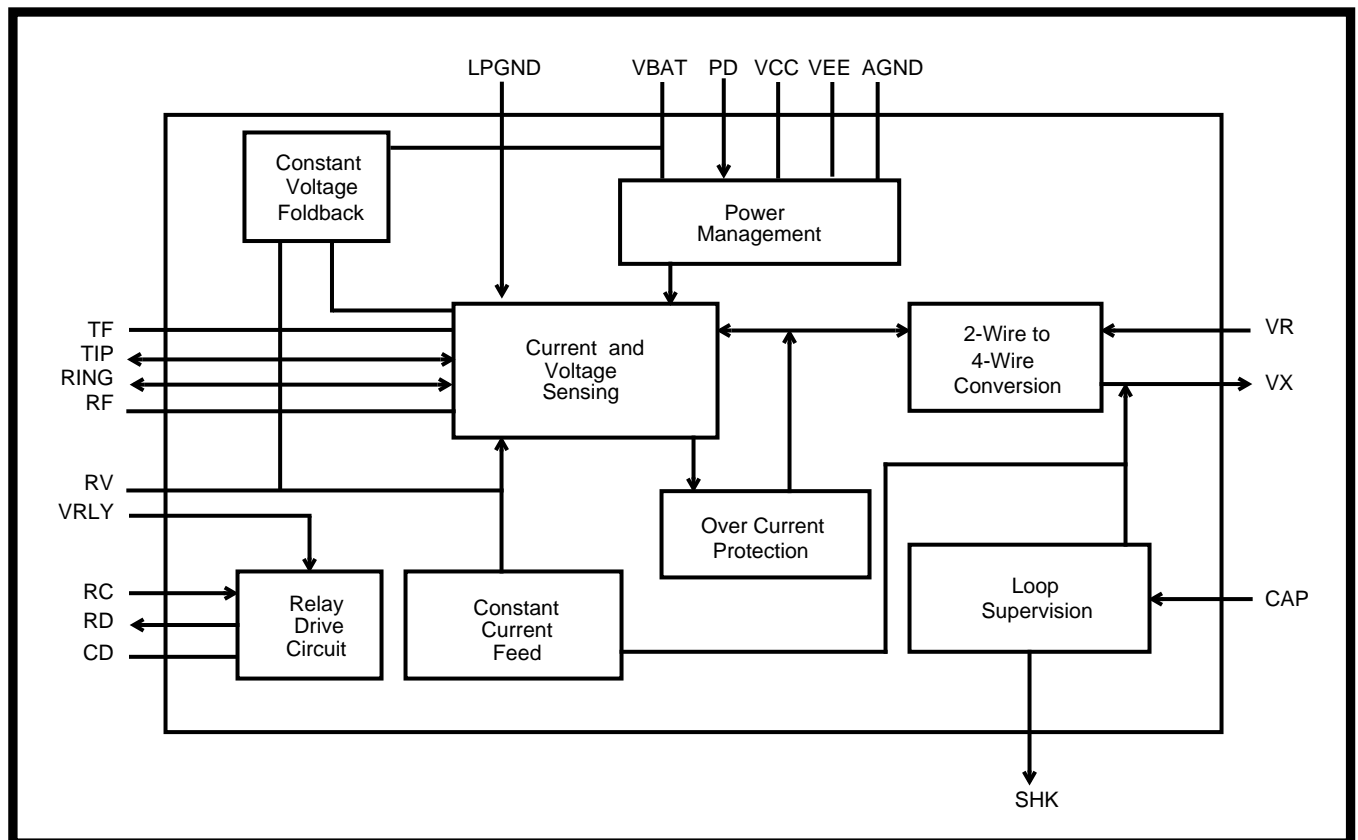

Figure 1 - Functional Block Diagram

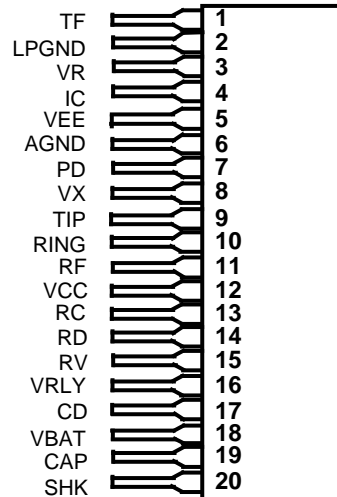

Figure 2 - Pin Connections

Pin Description

Pin #	Name	Description
1	TF	Tip Feed. Connects to external diode for protection
2	LPGND	Loop Ground. Is the system ground reference with respect to V_{BAT} . Normally connected to AGND.
3	VR	Voice Receive (Input). The 4 wire analog signal to the device.
4	IC	Internal Connection. No connection should be made to this pin
5	VEE	Negative Power Supply Voltage (-5V).
6	AGND	Analog Ground (0V).
7	\overline{PD}	Power Denial (Input). A logic high will isolate the battery voltage to Tip/Ring.
8	VX	Voice Transmit (Output). The 4-wire analog signal from the device.
9	TIP	Connects to the "Tip" lead of the telephone line.
10	RING	Connects to the "Ring" lead of the telephone line.
11	RF	Ring Feed (Input). Normally connected to Ring relay for negative battery feed voltage and ringing voltage input.
12	VCC	Positive Power Supply Voltage (+5V).
13	RC	Relay Control (Input). Active high.
14	RD	Relay Drive. Open collector sinks current when RC is at logic high.
15	RV	Ring Feed Voltage. Normally connected to pin 11 (RF) through a normally closed relay and to external diode protection.
16	VRLY	Relay voltage Supply (+5V).
17	CD	Clamping Diode. Normally connected to AGND.
18	VBAT	Negative Battery Feed Supply Voltage (-48V).
19	CAP	Normally connected via an external capacitor to ground to prevent false ring trip. Must be open circuit to allow dial pulse detection.
20	SHK	Switch Hook Detect (Output). Active high on/off-hook indicator.

Functional Description

The SLIC performs a transformerless 2-wire to 4-wire conversion of the analog signal. The 2-wire circuit is the balanced line going to the subscriber loop, while the 4-wire circuit is the audio signal going to and from devices such as the voice codec or switching circuit. The SLIC also provides a switch hook (SHK) status output which goes high when the telephone is set off-hook.

Constant Current Feed

The MH88612BV-K employs complex feedback circuits to supply a constant current feed or, if necessary, constant voltage feed to the line. With a nominal -48V battery the device will supply a constant current of typically 25mA to a line up to 1100Ω. For longer lines there is insufficient battery voltage so the device automatically switches to constant voltage mode where Tip and Ring will stay at their minimum and maximum voltage levels and the supplied current will be reduced accordingly. The maximum line resistance supported is 2000Ω including the telephone set.

Switch Hook Detection

The SHK pin will go to logic 1 to indicate that a telephone connected to the line has gone off-hook (closed loop). Off-hook will not be indicated if the loop resistance (including the telephone set) is too high for the device to support.

The SHK output will toggle to indicate dial pulses on the line. If the capacitor on CAP (Pin 19) has not been switched out of circuit the dial pulses will be distorted.

Ringing And Ring Trip Detection

In Figure 3 a ringing signal (e.g.90 Vrms and -48Vdc) is applied to the line by disconnecting pin 15 (RV) from pin 11(RF), and connecting the ringing voltage at pin 11 (RF) by use of the relay K1.

The SLIC can detect an off-hook condition during ringing but there is a large AC component which must be filtered out to give a true off-hook condition at SHK.

A 1.0μF capacitor connected from pin 19 (CAP) to ground will provide adequate attenuation when ringing is applied. Once an off-hook condition has been detected a logic low should be applied to pin 13 (RC) which will deactivate the relay (K1) to

disconnect the ringing voltage from pin 11 and reconnect to pin 15. At that time the SLIC will revert to constant current feed operation.

For applications requiring Dial Pulse Detection the Capacitor connection to ground should be controlled such that the capacitor is disconnected during Pulse Dialling.

During off-hook conditions (closed loop), the capacitor (C1) should not have a low impedance path to ground. This can be done using a transistor (Q1) and resistor (R2) as shown in Figure 3 with R2 providing a high impedance path for C1. When ringing is applied (RC = 5V) the transistor will short circuit R2 which will give C1 a low impedance path to ground and provide the required filtering.

Other methods can be used to switch out the capacitor such as a relay or a codec system drive output (with a similar configuration as above).

For applications using DTMF signalling, the capacitor can be permanently connected to ground.

Current Limit

The Tip or Ring of the telephone line may accidentally be shorted to ground. In such a case, current will only flow through the feed resistor. This high current will be sensed and reduced by the current limit circuit to a lower value to protect the internal circuitry.

Power Denial

The power denial function is a feature of the MH88612 which allows for powering down of the subscriber loop. A logic high voltage applied to the power denial input effectively removes the battery voltage from the loop driver circuitry. The resulting I_{LOOP} is negligible and power consumption is minimised. The power denial function is useful for disabling a loop which may have a ground fault.

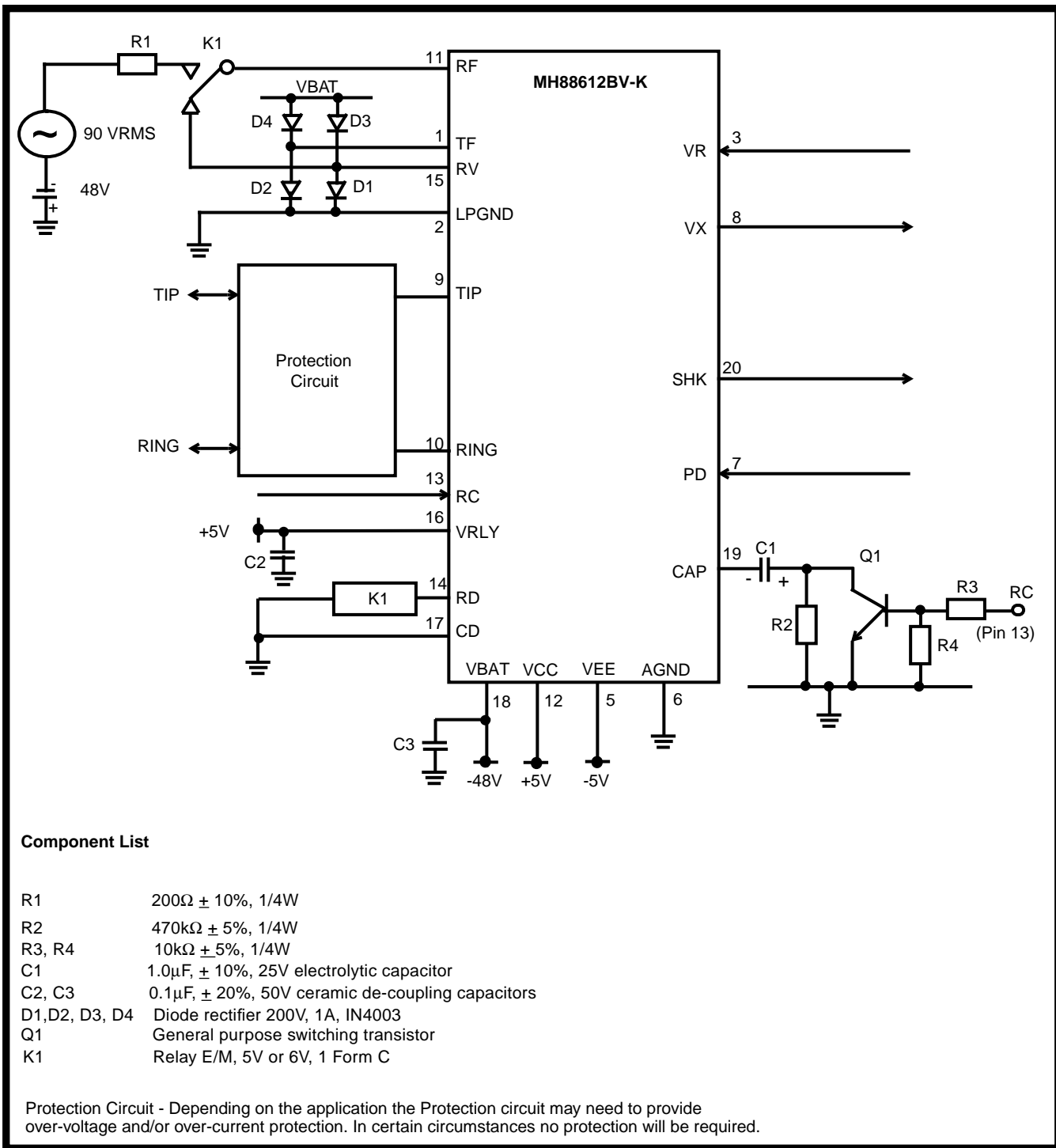

Figure 3 - Typical Application Circuit

Absolute Maximum Ratings*

	Parameter	Symbol	Min	Max	Units
1	DC Supply Voltage LPGND = AGND	V_{CC}	-0.3	15	V
		V_{EE}	-15	0.3	V
		V_{BAT}	-60	0.3	V
		V_{RLY}	-0.3	40	V
2	Storage Temperature	T_S	-40	100	°C
3	Package Power Dissipation	PD		2	W

* Exceeding these values may cause permanent damage. Functional operation under these conditions is not implied.

Recommended Operating Conditions

	Characteristics	Sym	Min	Typ*	Max	Units	Test Conditions
1	Operating Supply Voltage	V_{CC}	4.75	5.0	5.25	V	
		V_{EE}	-4.75	-5.0	-5.25	V	
		V_{BAT}	-42	-48	-54	V	
		V_{RLY}		5		V	
2	Relay Driver Current	I_{RLY}			100	mA	
3	Operating Temperature	T_o	0		70	°C	

*Typical figures are at 25°C with nominal 5V supplies and are for design aid only.

DC Electrical Characteristics[†] - Voltages are with respect to GNDA unless otherwise stated.

	Characteristics	Sym	Min	Typ*	Max	Units	Test Conditions
1	Supply Current V_{CC} V_{EE} V_{BAT}	I_{CC} I_{EE} I_{BAT}		7.5 -5.1 3	800	mA mA μ A mA	PD = Logic High PD = Logic Low, Idle
2	Power Consumption	P_C		160 1600		mW mW	Standby $V_{BAT} = -48V$ Active (Off Hook)
3	Constant Current Line Feed	I_{Loop}	23 15	25 16.5	27 19	mA mA	$R_{Loop} < 1100\Omega$ $R_{Loop} \leq 2000\Omega$ $V_{BAT} = -48V$
4	Operating Loop Resistance	R_{Loop}			2000	Ω	$V_{BAT} = -48V @ I_{Loop} = 16mA$, R_{Loop} includes telephone set
5	Ring Ground Over-Current protection				45	mA	$V_{BAT} = 48V$
6	Off-Hook Detect Output Low Voltage (On-hook) Output High Voltage (Off-hook)	V_{OL} V_{OH}	2.7		0.4	V V	Active high logic
7	Off-Hook Detect Output Low Current (On-hook) Output High Current (Off-hook)	I_{OL} I_{OH}			8 -200	mA μ A	
8	RC, PD Control Input Input Low Volt (no activation) Input High Volt (activation)	V_{IL} V_{IH}	2.0		0.7	V V	Active high logic LSTTL compatible
9	RC, PD control Input Input Low Current (no activation) Input high current (activation)	I_{IL} I_{IH}			50 0.5	μ A mA	
10	PD Control Input Input Low Current Input High Current	I_{IL} I_{IH}			0.5 0.3	mA mA	

[†] DC Electrical Characteristics are over recommended operating supply voltages.

*Typical figures are at 25°C with nominal 5V supplies and are for design aid only.

AC Electrical Characteristics

	Characteristics	Sym	Min	Typ*	Max	Units	Test Conditions
1	Ringing Voltage Frequency	V_{RING} F_{RING}	17		90 25	V_{rms} Hz	Superimposed on $V_{BAT} = -48V$
2	Ringer Equivalence Number	REN			2		
3	Ring Trip Detect time			200	300	ms	
4	Input AC Impedance 2-wire	Z_{in}		600		Ω	
5	Input Impedance at VR			100		$k\Omega$	
6	Output Impedance at VX			10		Ω	
7	Gain 2-wire to VX Gain relative to Gain @ 1kHz		-1.3 -0.3	-1.0	-0.7 +0.3	dB	Input 3dBm, 1kHz across Tip and Ring 300-3400 Hz
8	Gain VR to 2-wire Gain relative to Gain @ 1kHz		-1.3 -0.3	-1.0	-0.7 +0.3	dB dB	Input 1.0Vrms 1kHz at VR $Z_{Load} = 600\Omega$ 300 - 3400 Hz
9	2-wire Return Loss over 300-3400Hz		20	30		dB	Input 0.5Vrms, 1kHz across Tip and Ring, $Z_{Load} = 600\Omega$
10	Transhybrid Loss	THL	20	30		dB	300-3400 Hz $Z_{Load} = 600\Omega$
11	Longitudinal to Metallic Balance		40 46	55 55		dB dB	300-600Hz 600-3400Hz
12	Total Harmonic Distortion at VX at Tip and Ring	THD		0.1 0.1	1.0 1.0	% %	Input 3dBm, 1kHz across Tip and Ring, Input 1.0Vrms 1kHz at VR
13	Common Mode Rejection Ratio 2-wire to VX	CMRR	40	50		dB	Input 0.5Vrms, 1kHz
14	Idle channel Noise	Nc			14	dBrnC	@ 2 Wire and VX C- Message weighted
15	Power supply rejection ratio V_{CC} V_{EE} V_{BAT}	PSRR	26 26 26			dB dB dB	100 mV _{PP} ripple, 1kHz on $V_{CC}/V_{EE}/V_{BAT}$, measure at VX and across Tip and Ring

*Typical figure are at 25°C and are for design aid only.

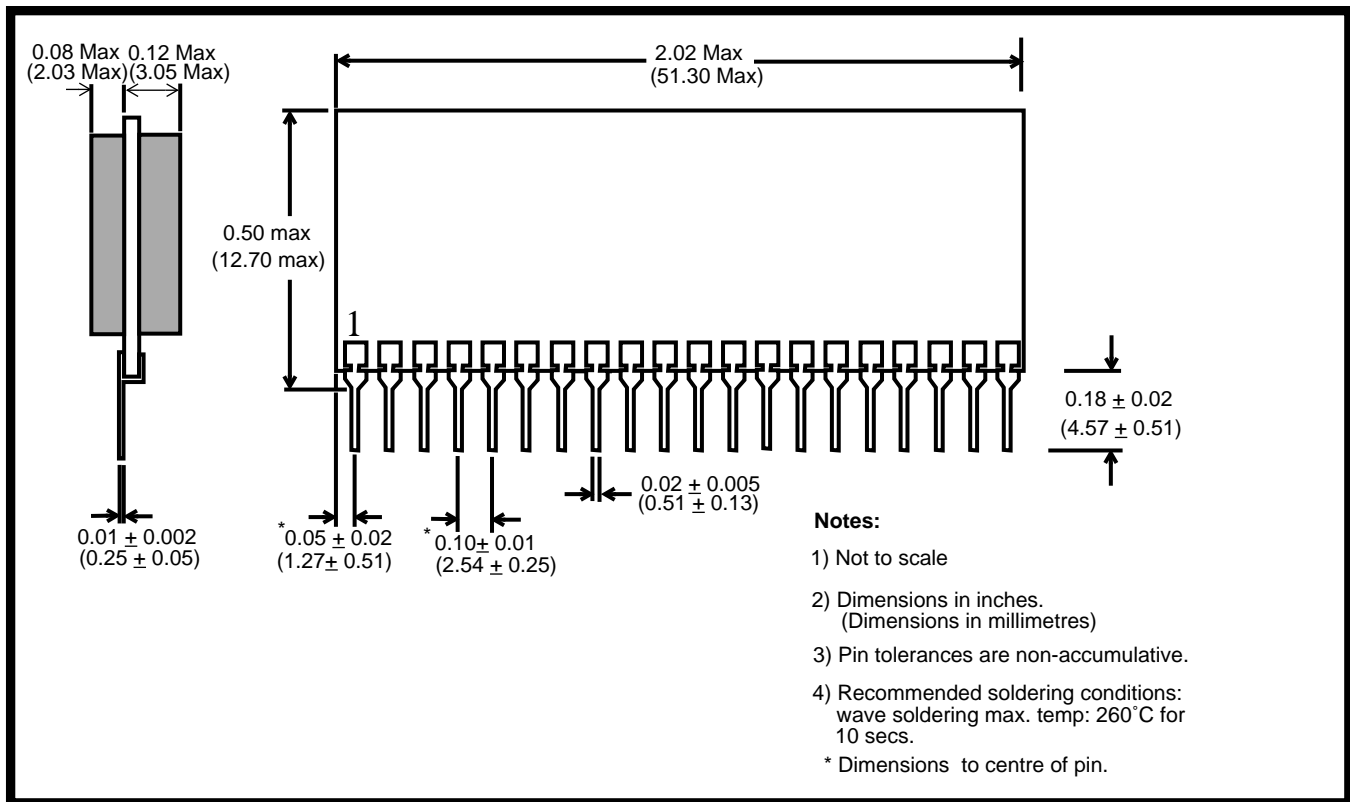

Figure 4 - Mechanical Data